



Eclipse Low Fog Generator

Operators Manual

For G3000 and PFI9D

Table of Contents

Introduction	1
Water Base Fog Technology	1
Eclipse Low Fog Technology	1
Warning	1
Important Safety Instructions	1
Safety Precautions	2
Eclipse Low Fog Generator	3
Technical Drawings	3
Technical Specifications	3
Eclipse Low Fog Effects Generator w/Cart+G3000	4
Technical Drawings	4
Technical Specifications	4
Eclipse Low Fog Effects Generator w/Roadcase+G3000	5
Technical Drawings	5
Technical Specifications	5
Eclipse Low Fog Effects Generator w/Cart+9D	6
Technical Drawings	6
Technical Specifications	6
Eclipse Low Fog Effects Generator w/Roadcase+9D	7
Technical Drawings	7
Technical Specifications	7
Operating Procedure	8
G3000/PFI9D/ECLIPSE machine setup	8
Using High Pressure CO2 cylinders with syphon	8
Using Low Pressure 350 lb. Dewar Tank	9
Refrigerated Liquid Dewars Explained	10
Eclipse Operation with the G3000	11
Digital Remote Operation	11
DMX Operation	12
Eclipse Operation with the PFI9D	13
DMX Operation	13
Optional Timer/Duration Remote Operation	13
Optional Show Control Remote Operation	14
Show Control Operation	15
Disconnecting the G3000/PFI9D and Eclipse	15
Ducting	16
Troubleshooting Residual Buildup and Wet Output	17
Maintenance	18
Recommended Fluid	18
Warranty	19
Contact Information	20

Note: Please read entire manual before operating the Eclipse Low Fog Generator

Introduction

Water Base Fog Technology

Water Base Fog Technology is achieved by pumping a glycol/water mixture through a heat exchanger. This will vaporize the fluid as it passes through the processing block. The vaporization of the fluids force the hot mixture through the output nozzle. When mixed with ambient air, it forms an opaque aerosol (fog). The fog is made up of tiny droplets that form around the small particles in the air. The suspended droplets refract the light, allowing the fog to take on the color of the light illuminating it.

Eclipse Low Fog Technology

The advanced Eclipse technology uses liquid CO₂ to cool the fog, generating a consistent effect at sub zero temperatures. This process enables you to produce large quantities of low lying fog on a continuous basis without cue time limitations or the messy water residue associated with other technologies. The Eclipse is compact and mobile facilitating most applications.

The unique partnering of a fog effect with liquid CO₂ is cost effective while providing a longer lasting effect. Designed to be utilized with the Eclipse, the Ultratec Special Effects genuine 'Molecular Fog Fluid' provides a dry, thick, white effect with a consistent dissipation that eliminates any ambient hazing. The "Eclipse" couples with the G3000, offering the most advanced controls and fog output available. The Eclipse consumes approximately 8 lbs. of Liquid Carbon Dioxide per minute of operation.

The system can be controlled via the attached fog machines integral controls, DMX or show control.

The Eclipse Interface allows the Eclipse & Fog Machine to be controlled on separate DMX channels. Standard equipment includes 10" ducting sleeve to facilitate standard ducting in many configurations based on fog distribution requirements.



Warning!!

High pressure gas/liquid. Safety Hazard!

Refrigerated liquids at low temperature. Burn Hazard!

High Temperature contact points on fog machine nozzle. Burn Hazard!

Condensed fluid accumulation. Slip Hazard!



Important Safety Instructions

1. Do not remove the outer case.
2. Persons suffering from asthma or allergenic sensitivity may experience irritation, discomfort or allergic symptoms when exposed to fog effects.
3. Ensure that this unit is grounded at all times. Failure to do so may result in serious injury.
4. Use Ultratec Special Effects fluid **ONLY**.



Safety Precautions

1. Ensure that any operation of the machine is supervised by suitably trained and authorized personnel.
2. Do not modify the machine or use a machine which has been damaged in any way.
3. Allow sufficient air circulation around the machine at all times.
4. Protect the machine from direct weather effects and wet locations.
5. Only use fluids manufactured by Ultratec Special Effects.
6. Do not continue to produce fog when visibility is reduced to 20" 50cm or below.
7. Avoid directing fog output continuously at people, structures or objects within close proximity of the discharge nozzle.
8. Ensure that adequate exhausting arrangements are available in the event of an emergency.
9. Do not place hands or exposed skin within the first 20" (50 cm) of the discharge nozzle at any time during fog production.
10. Fog effects will trigger smoke alarms and detectors. Please take suitable precautions to prevent false alarms.
11. Ensure sufficient air exchange vs. CO2 released.

CO2 is heavier than air and will pool in higher concentrations in lower lying areas like orchestra pits and below stage.

Eclipse Low Fog Effects Generator

CLF-4000 Eclipse Low Fog Effects Generator 110V
CLF-4004 Eclipse Low Fog Effects Generator 220V

Technical Drawings

Top

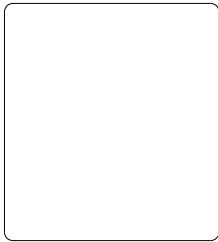

Back

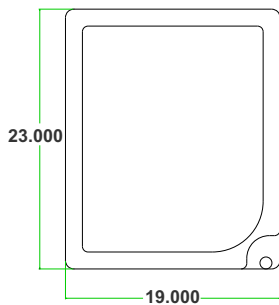

Left Side

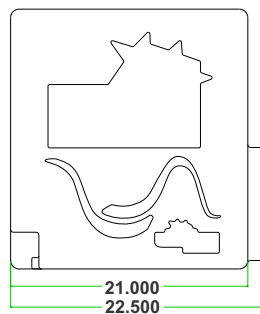

Front

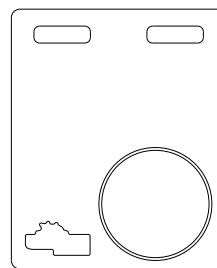

Right Side

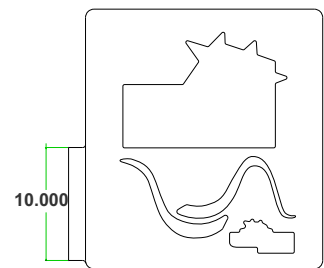

Technical Specifications

Length: 22.5 in / 57 cm
Width: 19 in / 48 cm
Height: 23 in / 58 cm
Net Weight: 47 lbs / 20 kg
Power Cord: 5 ft - 1.5 m interconnect cord
Rating: 1 Amp AC @ 120 volts @ 50/60 hz
Regulatory Compliance: This product has been certified to CSA/UL

Note: Specifications are based on the Eclipse machine only.
Specification Footnote:

CO2 Usage

High Pressure - approx. 8 lbs./ Min.
Low Pressure - approx. 8 lbs./ Min.

Eclipse Low Fog Effects Generator w/Cart+G3000

CLF-4052 Eclipse Low Fog Effects Generator w/Cart+G3000 110V
CLF-4053 Eclipse Low Fog Effects Generator w/Cart+G3000 220V

Technical Drawings

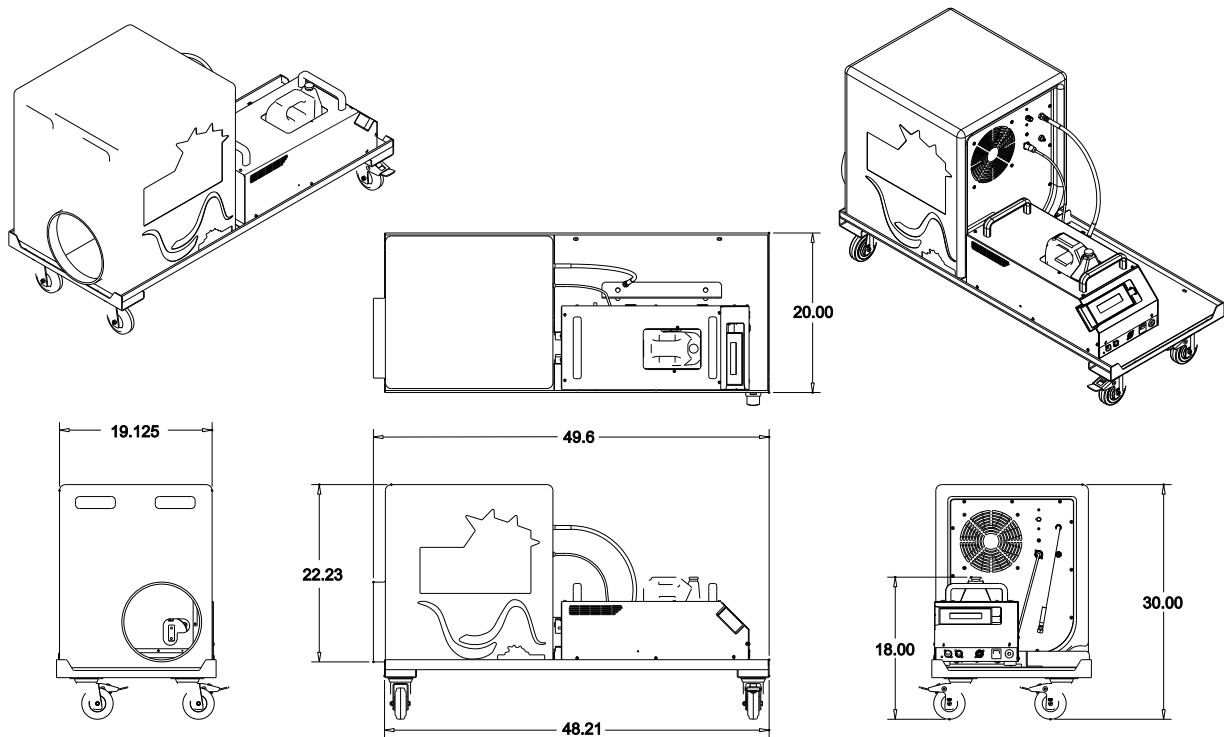

Technical Specifications

Length: 48.21 in/12.45 cm
Width: 19.12 in/48.56 cm
Height: 30 in/76.20 cm
Net Weight: 123 lbs/56 kg
Power Cord: 5 ft - 1.5 m interconnect cord
Rating: 18 Amp AC @ 120 volts @ 50/60 hz
Regulatory Compliance: This product has been certified to CSA/UL

Note: Specifications are based on the Eclipse and the G3000 combined.
Specification Footnote:

CO2 Usage

High Pressure - approx. 8 lbs./ Min.
Low Pressure - approx. 8 lbs./ Min.

Eclipse Low Fog Effects Generator w/Roadcase+G3000

CLF-4062 Eclipse Low Fog Effects Generator w/Roadcase+G3000 110V
CLF-4063 Eclipse Low Fog Effects Generator w/Roadcase+G3000 220V

Technical Drawings

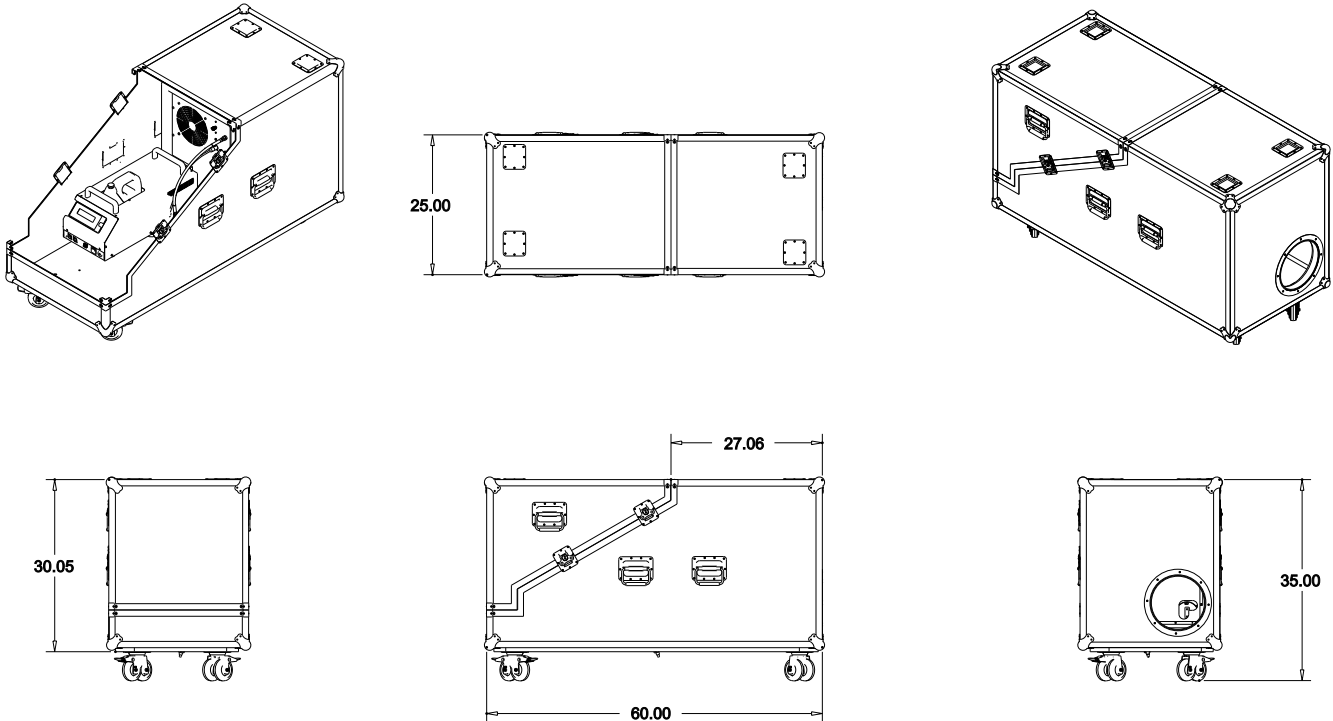

Technical Specifications

Length: 60 in/152.4 cm
Width: 25 in/63.5 cm
Height: 35 in/88.9 cm
Net Weight: 216 lbs/98 kg
Power Cord: 5 ft - 1.5 m interconnect cord
Rating: 18 Amp AC @ 120 volts @ 50/60 hz
Regulatory Compliance: This product has been certified to CSA/UL

Note: Specifications are based on the Eclipse and the G3000 combined.
Specification Footnote:

CO2 Usage

High Pressure - approx. 8 lbs./ Min.
Low Pressure - approx. 8 lbs./ Min.

Eclipse Low Fog Effects Generator w/Cart+9D

CLF-4072 Eclipse Low Fog Effects Generator w/Cart+9D 110V
CLF-4073 Eclipse Low Fog Effects Generator w/Cart+9D 220V

Technical Drawings

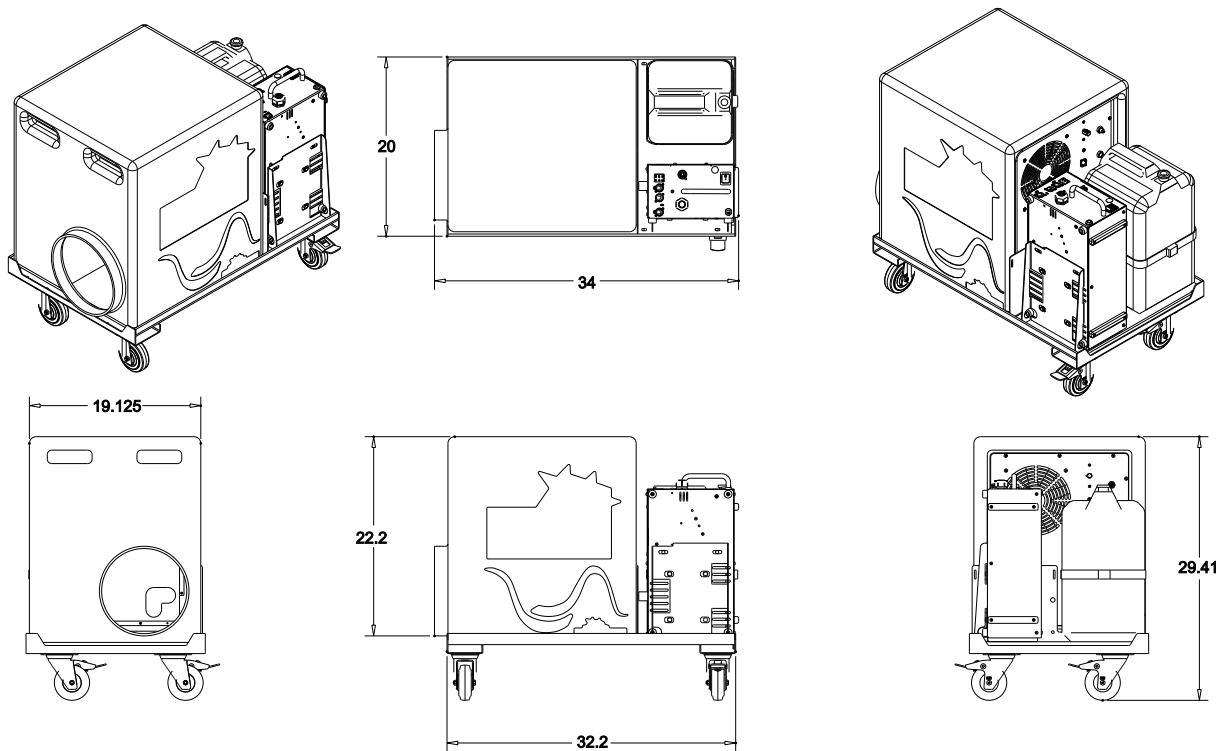

Technical Specifications

Length: 32.2 in/81.7cm
Width: 19.25 in/48.9 cm
Height: 29.41 in/74.7 cm
Net Weight: 110 lbs/50 kg
Power Cord: 5 ft - 1.5 m interconnect cord
Rating: 14 Amp AC @ 120 volts @ 50/60 hz
Regulatory Compliance: This product has been certified to CSA/UL

Note: Specifications are based on the Eclipse and the PFI9D combined.
Specification Footnote:

CO2 Usage

High Pressure - approx. 8 lbs./ Min.
Low Pressure - approx. 8 lbs./ Min.

Eclipse Low Fog Effects Generator w/Roadcase+9D

CLF-4082 Eclipse Low Fog Effects Generator w/Roadcase+9D 110V
CLF-4083 Eclipse Low Fog Effects Generator w/Roadcase+9D 220V

Technical Drawings

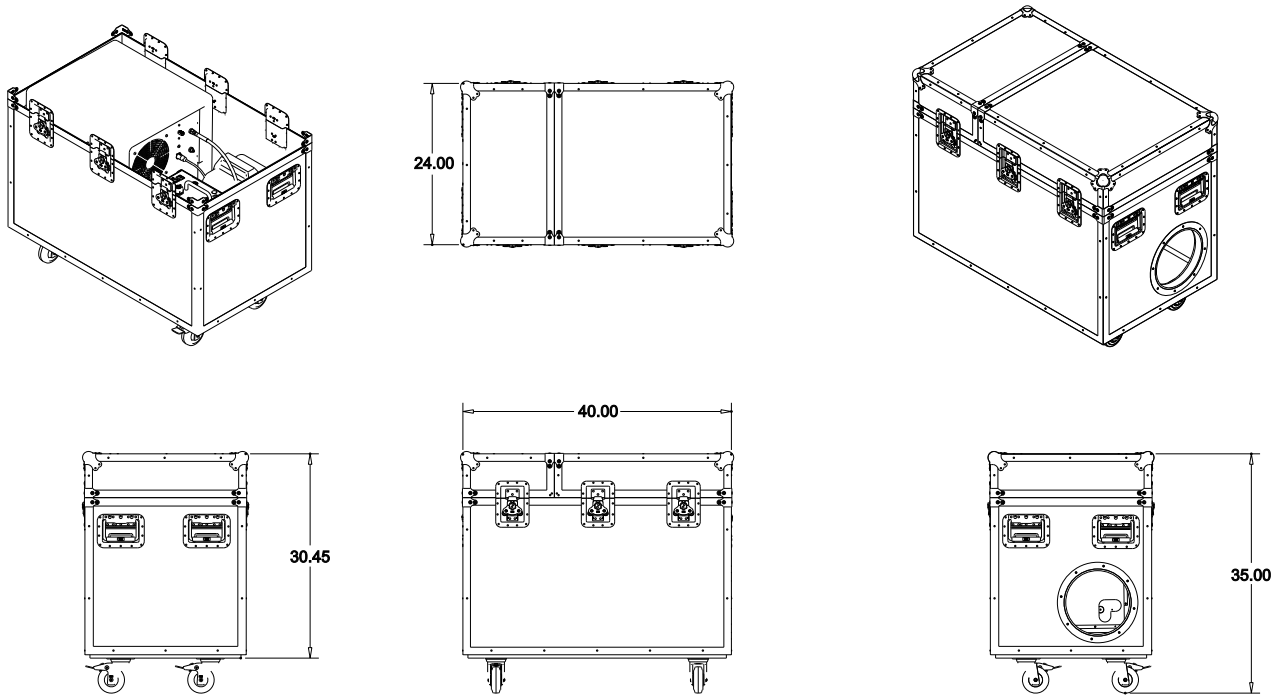

Technical Specifications

Length: 40 in./
Width: 24 in./
Height: 35 in./
Net Weight: 202 lbs/92 kg
Power Cord: 5 ft - 1.5 m interconnect cord
Rating: 14 Amp AC @ 120 volts @ 50/60 hz
Regulatory Compliance: This product has been certified to CSA/UL

Note: Specifications are based on the Eclipse and the PFI9D combined.
Specification Footnote:

CO2 Usage

High Pressure - approx. 8 lbs./ Min.
Low Pressure - approx. 8 lbs./ Min.

OPERATING PROCEDURE

G3000/PFI9D/ECLIPSE machine setup

- 1) Remove the 4" Adapter off the front of the fog machine (if equipped).
- 2) Place the fog machine output end directly against the foam gasket of the ECLIPSE aligning the output nozzle with the hole.

TECH TIP: Proper alignment can be observed by shining a flashlight into the 10" output opening of the ECLIPSE.

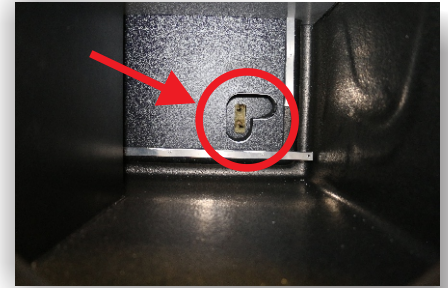

- 3) Connect the power cable by connecting the grey Neutrik end to the fog machine and the black Neutrik end to the Eclipse. Turn until you hear the click when it locks.
- 4) Insert the fluid tube into a jug of Molecular Fog Fluid and secure it making sure the fluid filter reaches the bottom of the jug.
- 5) Heat up the fog machine by turning the power switch to the on position. The fog machine will take approximately 10 minutes to fully heat up.

Note: For G3000 system a 20-amp circuit is required for 120-volt operation.
For PFI9D system a 15-amp circuit breaker is required.

Using High Pressure CO2 cylinders with syphon tube

- 1) Connect the CO2
- 2) Using a white nylon or black fiber washer, connect the other end of the supply hose to the high pressure CO2 tank.
- 3) Tighten both CO2 supply fittings snug with an appropriate wrench.
- 4) Open valve on CO2 tank slowly to check for leaks then open fully, by turning counterclockwise.



Using Low Pressure 350 lb. Dewar Tank

- 1) Connect CO2 hose to bottom valve on Eclipse (labeled Refrigerated or Low Pressure). The second connection must be to the Liquid output of the Liquid CO2 Dewar Tank. This is usually clearly indicated on the Liquid CO2 Tank output. Depending on the type of fitting provided for the liquid output on the Dewar tank, a sealing washer may be necessary to prevent leaks when connecting the CO2 hose to the tank. This will normally require the use of the 320 to 622 fitting adapter.
- 2) Tighten the CO2 supply fittings snug with appropriate wrench.
- 3) The Liquid CO2 Tank pressure as indicated on the pressure gauge must read between 300-340 psi to operate the Eclipse. This is achieved by opening the pressure builder valve at least one to three hours in advance of use; by turning it fully counterclockwise.

NOTE: Dewar operation requires it to consume some of the CO2 to keep it cold. Dewars must be store where some venting can safely be tolerated. Venting can be extremely noisy and releases CO2 gas out of the dewar vent port.

- 4) Open the liquid CO2 valve slowly to check for leaks then open fully, by turning counterclockwise.



Refrigerated Liquid Dewars Explained

The Eclipse Low Pressure valve uses CO2 Cylinders similar to the one pictured to the right. These are available from the local welding supply center, and are sometimes referred to as "Dewars". Typically, there are three valve handles, a pressure gauge and a CO2 level indicator located on the top of the Liquid CO2 Tank. These valves handles should be labeled as Gas/Vent, Liquid and Pressure Builder.



We will cover each of these below.

Liquid Supply

This is the source of our liquid supply of CO2. The Eclipse CO2 supply hose is threaded onto the valve outlet, being sure to use the appropriate sealing washer and tighten to eliminate any leaks.

When ready to operate the Eclipse, open the Liquid valve fully by turning counterclockwise and then close 1/4 turn.

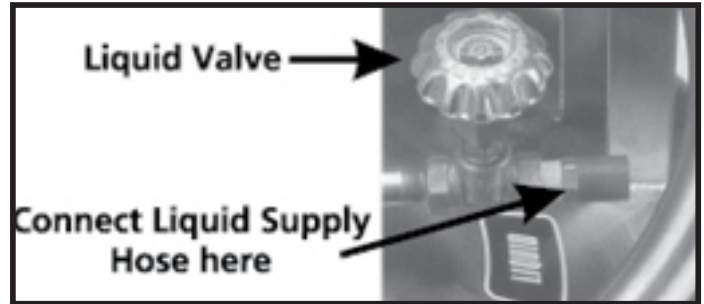

Gas Supply

This is used if a CO2 gas supply is utilized. As we only use the liquid supply to operate the Eclipse, this valve is not opened

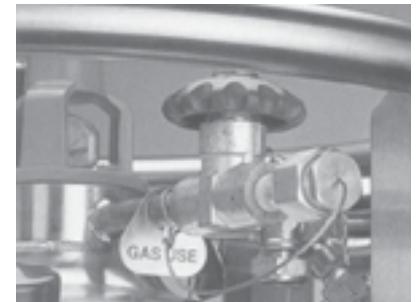

Pressure Builder

The pressure builder is a very important component in achieving the proper Eclipse operating pressure. We can monitor this operating pressure by observing the pressure gauge located on the top of the Liquid CO2 Tank. Ideally the operating pressure of the Liquid CO2 Tank is 300 - 330 PSI. This is achieved by opening the pressure builder valve prior to operating the Eclipse.

TECH TIP: Building the pressure to the proper level may take up to an hour, so it is suggested that the Pressure Builder valve be fully opened one to three hours before use.

NOTE: The Liquid CO2 Tank is equipped with a pressure relief valve that is fixed to open at 350 PSI. The pressure relief valve is in place to ensure the internal Liquid CO2 Tank pressure does not exceed 350 PSI. As you approach the ideal operating pressure the relief valve may open slightly and release CO2 gas. Although this is sometimes noisy this is no cause for alarm, simply close the pressure builder valve by turning clockwise.

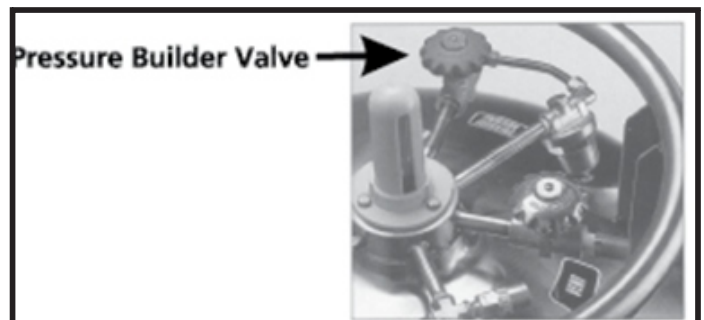

NOTE: These tanks vent 1-2% daily to maintain their cold temperature. They must be stored in a well-ventilated area to prevent dangerous CO2 accumulation.

Eclipse Operation with the G3000

Digital Remote Operation.

- 1) Adjust the remote flow rate “D” (demand) using + and – buttons to desired fog output level. We recommend starting at 30% and then adjust accordingly if need be. The maximum recommended flow for the G3000 is **50%**. If you find that the fog is not staying low to the floor (when running) reduce your flow rate accordingly until it does and check that you still have enough liquid CO2 in your tank.
- 2) To set the cycle time of the effect, press the menu button on the G3000 to “Set Cycle On”. Choose the time frame required. If you do not require a preset cycle time leave setting at 0:01 and press menu to select and go to the next screen.
- 3) If cycle time is required, “Set Cycle Off” time. If not needed, leave this setting at 0:00 and press the menu to select and go to the next screen.
- 4) To set the CO2 line purge, set **LSG PRE FOG TIME or CO2 PRE FOG TIME** to appropriate minutes/seconds depending on how long the CO2 hose is. To calculate the delay-time use 1 second for every 3 feet of hose. Example for 10' of hose between your tank and Eclipse, your PRE-FOG TIME minimum would be 0:04. It is good practice to add some extra time (5-10 seconds) to allow the Eclipse to pre-chill before adding fog. You will want more pre-chill if the output is piped some distance to a floor pocket or fog curtain.
- 5) Press Menu button again to change screen to DMX menu, and press Menu button again for Low Fluid Stop menu. Set Low Fluid Stop to “Off” or “On” if needed. When set to “On” the fluid pumps will stop automatically when a low fluid level is detected when the fluid bottle is in the jug holder. **TECH TIP:** Leave the setting at “Off” when using a G3000 with a 5' industrial hose.
- 6) Press Menu button again to change screen to next menu selection. Screen will be back to main menu. Ensure that fog machine is fully heated by looking at the right side of the screen. The temperature bar graph will be to the top and the letter H in the bottom right will no longer be displayed. Press I/O button to turn fog output “On” or “Off”.
- 7) The PRE-FOG TIME that was set will show up in the bottom left side and start to count down. The letter “R” will show up on the bottom right side of the screen. The Eclipse high and low pressure valves will open, and fan will turn on (The desired fan speed of the Eclipse can be set with the speed control dial to the right of the fan).
- 8) When the Eclipse is started (and has not run in several minutes) you will hear the valve open and a sharp hissing noise as the CO2 gas first starts. Within a few seconds the noise will soften to a liquid flow as the lines get chilled and at this point cold white CO2 cloud will be coming out the front of the Eclipse. Note: This should happen before the fog machine turns the pumps on if the PRE-FOG TIME is set correctly.

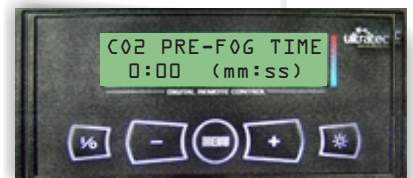

- 9) Once the PRE-FOG TIME countdown reaches 0:00, the fluid pumps will start at the set flow rate (Demand). Fog will start to flow out the Eclipse. It might take a few seconds for the fog to start staying close to the floor if the flow rate is correct. Best mixing of the fog and CO2 occurs if there is a piece of 10" tube (5') on the output nozzle. If you find that the fog is not staying close to the floor after a few seconds, reduce your flow rate accordingly and confirm that you still have liquid Co2 left in the tank.
- 10) If you have set the ON / OFF cycle timers mentioned previously, the next time that is displayed in the bottom left of the screen will be first be the ON time and once that reaches 0:00 the next time that is shown is the OFF time at which point the fluid pumps will stop and the Eclipse will turn Off. Once the Off time reaches 0:00 the time will switch back to the PRE-FOG TIME again and the whole process starts over again.

DMX Operation

Note: The G3000 requires 2 channels of DMX for the Eclipse to operate.

- 1) Attach a DMX signal to the "DMX IN" 5 pin connector on the rear of the unit. For good DMX practice, a terminator is used on the "DMX OUT" connector.
- 2) Select a valid DMX address on the digital remote.
- 3) Data = fog rate controlled 0-100%, DMX+1=Eclipse power turns on above 50%.
- 4) Valid DMX LED on the back of the G3000 is on solid if good DMX signal is present. Slow or irregular flashing indicates a poor DMX signal. DMX control overrides the digital remote flow, Cycle timers and PRE-FOG TIME settings.
- 5) The screen will show the words DMX and the set DMX address at the bottom left.
- 6) Select the 2nd consecutive DMX channel that you have set above 50% to turn On the Eclipse first. This is the equivalent to the PRE-FOG TIME and you have to count the delay time, as it is not automatic like when you are using the digital remote (Unless you are using a DMX console that you can preprogram timed queues).
- 7) The screen will show the letter "R" in the bottom right to indicate the Eclipse is powered On.
- 8) The Eclipse high and low pressure valves will open, and fan will turn on (You can set the desired speed of the fan on the Eclipse with the speed control dial to the right of the fan).
- 9) When the Eclipse is started (and has not run in several minutes) you will hear the valve open and a sharp hissing noise as the CO2 gas first starts. Within a few seconds the noise will soften to a liquid flow as the lines get chilled and at this point cold white CO2 cloud will be coming out the front of the Eclipse. Note: This is done before turning on the fog machine pumps.
- 10) Now bring up the 1st DMX channel to the desired flow to turn the fluid pumps On. We recommended 30% as shown on the digital remote display "D" (demand). **Do not exceed 50% demand setting.** If you find that the fog is not staying close to the floor after a few seconds, reduce your flow rate accordingly and confirm that you still have liquid Co2 flowing from the tank.



- 11) Example: DMX address set 122 in digital remote. Turn up DMX channel 123 over 50% preferably 100%. Count off your required purge and pre-chill time and then bring up DMX channel 122 to the desired flow rate. Once again not exceeding 50% maximum; 30% or lower is recommended. Please note: % on a DMX fader is not the same as % showing on the digital display "D" flow setting. Please view the digital remote's flow setting for the actual flow rate being demanded.

Eclipse Operation with the PFI9D

DMX Operation

The Power Fogger Industrial 9D is equipped with DMX controls as a standard feature.

- 1) Attach a DMX signal to the DMX IN 5 pin connector on the rear of the unit. A terminator may be required on the DMX OUT connector in some applications.
- 2) Select a valid DMX address on the digital display selector for the base address of the fogger. If an air option is present 3 consecutive address will be required. Base DMX= fog rate controlled 0-100%, DMX+1=ECLIPSE power on above 50%, and DMX+2= air on above 50%.
- 3) Valid DMX LED is on solid if good DMX signal is present. DMX control overrides hand remote. Slow or irregular flashing indicates poor DMX data.
- 4) Select the 2nd consecutive DMX channel that you have set above 50% to turn on both Eclipse valves and to turn on the fan (You can set the desired speed of the fan on the Eclipse with the speed control dial to the right of the fan)
- 5) Now bring up the 1st DMX channel to the desired flow rate to turn the fog output ON. We recommend a maximum of 30%. **Do not exceed 50% flow rate setting.** If you find that the fog is not staying close to the floor after a few seconds, reduce your flow rate accordingly and confirm that you still have liquid Co2 flowing from the tank.
- 6) Verify cool temperature output by using your hand and passing it through the fog-CO2 output noting the temperature.

Note: For specific 9D Fog Machine operation, refer to the 9D operator's manual.

Eclipse Operation with the PFI9D (Contd.)

Optional Timer/ Duration Remote Operation

The Timer/ Duration Remote offers Duration, Interval, Variflow and fog on/ off controls.

Timer/ Duration Remote LED Indicator

The Timer/ Duration Remote Handset was designed to indicate operation modes. These are as follows:

Slow Flashing Light: Indicates unit is not ready to operate but still in heating mode, fog is not available at this point.

Quick Flashing Light: Indicates unit is ready to operate but still in heating mode, some fog is available at this point.

Solid Light: Indicates that the unit is ready to fog at full output.

Triple Pattern Flashing Light: Indicates that the unit is in an over temperature condition and has shut down.

No Light: Indicates problems; a loss of power or remote is not connected. If these fail to correct the problem, contact your local Ultratec Special Effects dealer.

Note: To operate the ECLIPSE using the Timer/ Duration Remote, the DMX Address must be set on 555. A show Control Remote and Timer/ Duration Remote cable may be extended from the machine and operated effectively away from the Power Fog Industrial. The maximum recommended cable length is 225 Feet.

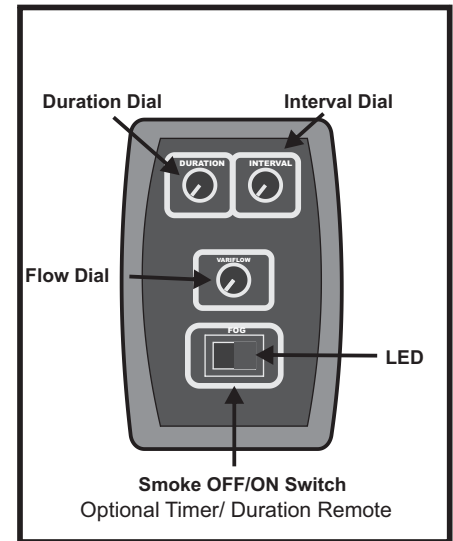

Optional Show Control Remote Operation

The Show Control Remote Handset LED was designed to indicate operation modes. These are as follows:

Slow Flashing Light: Indicates unit is not ready to operate but still in heating mode, fog is not available at this point.

Quick Flashing Light: Indicates unit is ready to operate but still in heating mode, some fog is available at this point.

Solid Light: Indicates that the unit is ready to fog at full output.

Triple Pattern Flashing Light: Indicates that the unit is in an over temperature condition and has shut down.

No Light: Indicates problems; a loss of power or remote is not connected. If these fail to correct the problem, contact your local Ultratec Special Effects dealer.

Show Control Operation

Show control is achieved by connecting a “Dry” or zero voltage contact to the show control terminals. The Power Fog Industrial 9D requires no power to signal the fog, only one set of contacts that close for the entire fogging cue.

For Show Control Operation, the DMX Address must be set on 555. Closing the Show Control Remote terminals with dry contacts, triggers the following machine functions:

C + 1 = Fog On/ Off w/ Variflow

C + 2 = ECLIPSE On

C + 3 = Air Option

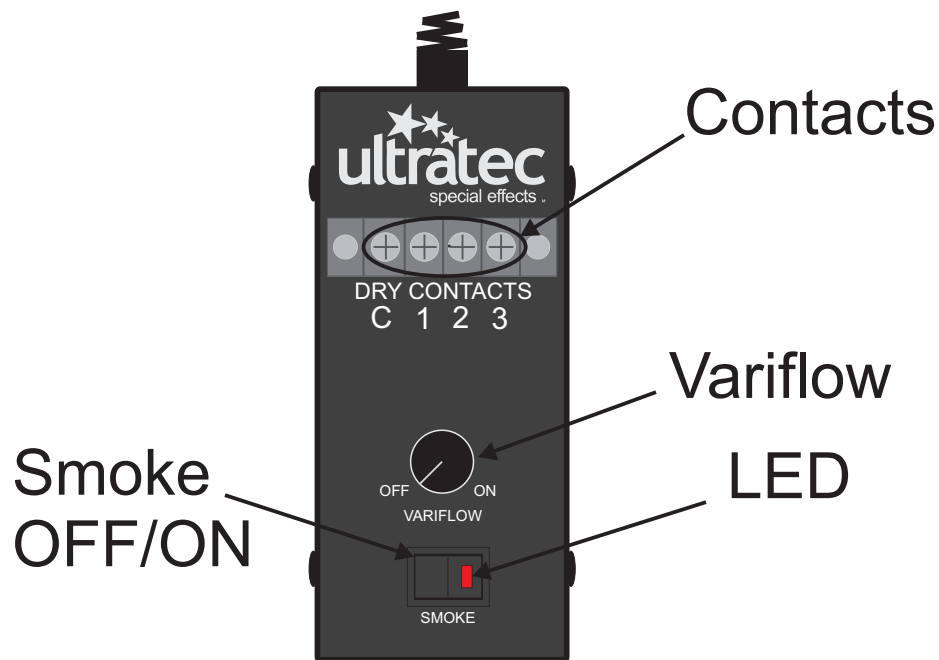

Disconnecting the G3000/PFI9D and Eclipse

- 1) Close the CO2 tank valve (and pressure builder valve if using a Dewar tank)
- 2) Turn on the **Eclipse only** to run out the CO2 from the lines and Eclipse valve. This may take several cycles of the Eclipse to purge the line. Do not make fog at this time. When the hissing noise stops is an indicator that the lines are now empty.
- 3) With Caution disconnect the CO2 hose from the tank and Eclipse.
- 4) Disconnect the cable from the fog machine to the Eclipse.
- 5) Drain any condensate which has accumulated in the Eclipse.

Ducting

If ducting is required the ECLIPSE Low Fog Generator output requires a 10" flexible duct, and can be ducted up to 50 feet horizontally. The ducting is available insulated or non-insulated and can be purchased through an industrial supply company or from Ultratec Special Effects.



CLF-2956 Non-insulated 10" Hose
25' w/10" Hose Clamp.

The ECLIPSE Low Fog Generator may also be ducted vertically up to 20 feet to produce a waterfall or cascade effect. When ducting fog vertically, the remaining fog in the duct must not be allowed to backflow into the ECLIPSE Low Fog Generator.

When this happens repeatedly the glycol in the fog may condensate on the inside of the G3000, damaging the electronic components. See further in this manual for suggested solutions and ducting examples.

TECH TIP: If dividing the output to more than one location while ducting, make sure the sum of all cross sectional areas of the final duct sizes are equivalent or greater than the cross sectional area of the ECLIPSE Low Fog Generator 10" outlet. Doing this will prevent any backpressure being created by the ECLIPSE Low Fog Generator. The formula for cross sectional area: $0.78539 \times (\text{diameter squared})$

Example:

The ECLIPSE Low Fog Generator outlet has a diameter of 10":
 $0.78539 \times 100 = 78.5$ square inches is the area of the ECLIPSE Low Fog Generator outlet.

If you require 3 locations to duct the effect to, then the cross sectional area of the 3 ducts must be greater than 78.5" square inches.

For this example, we will try a 6" diameter duct: $0.78539 \times 36 = 28$

If we multiply the cross sectional area of the 6" duct by 3 duct outlets : $28 \times 3 = 84$. 84 is greater than 78.5 so the 6" ducting split into 3 ducts is acceptable. Some form of dampening may have to be used to balance the output of different sized outputs.

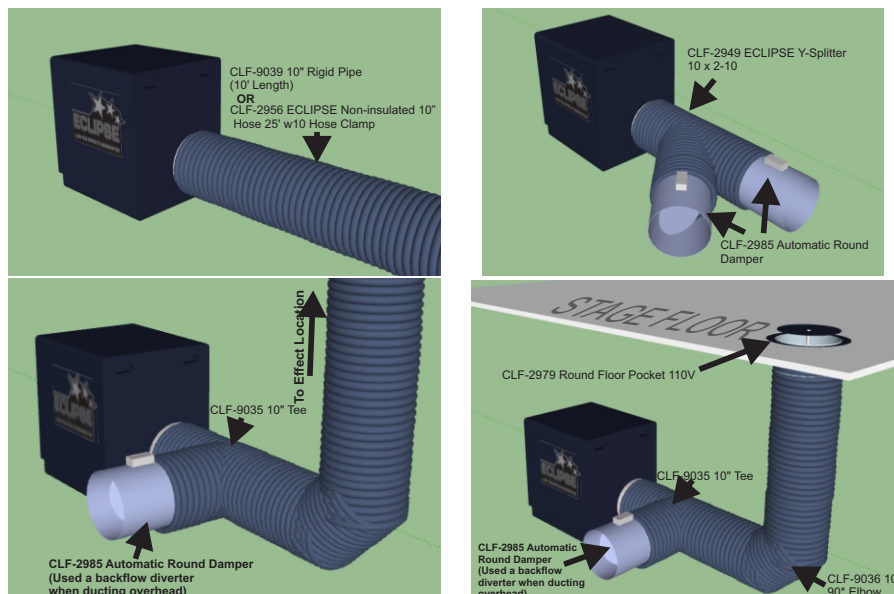

Troubleshooting Residual Buildup and Wet Output

The following list of items may cause wet output or residue to form:

1. Low CO2 Pressure, less than 275 PSI. Check to ensure the Pressure Builder Valve is turned on and the pressure is over 300 PSI. before use. Monitor the pressure through the cue to see if the pressure does not drop below 275 PSI. If it does, freeze up can occur which can lead to residue forming.
2. With the use of Mini Dewars this some times becomes a problem. Some mini dewars may not be able to sustain sufficient pressure during running. This can be over come by adding regulated CO2 gas (300-340 psi) to the gas port allowing sufficient liquid to flow.
3. The ECLIPSE must always use the Liquid CO2 from the Liquid CO2 Tank **NOT** the Vapor.
4. If using ducting the duct may have a kink or some kind of obstruction in it.
5. Fog flow is not straight out of the fog machine. These must be adjusted to ensure the fog can fully expand. Visually check the copper tubes at the fog machine output to ensure the fog is exiting the output. If they are not, use a pair of pliers and adjust. (Be careful as they may be extremely HOT).
6. Fog Machine is not lined up with the entry hole. This is where the fog machine meets the ECLIPSE. If this does not meet direct and straight the fog can not expand fully. Take a flashlight and shine it through the 10" opening of the ECLIPSE and look through to the input to see if it is lined up properly.
7. The fog machine is not processing the fog properly. Remove the machine from the ECLIPSE, turn on the fog machine and place your hand in the fog stream 24" away from the front of the machine. Your hand should be dry. You will feel a slight warming but do not confuse this for moisture. If the machine is not performing properly, your hand will be very wet. The fog machine should be serviced to rectify the problem.
8. Too much fog is being pushed through the ECLIPSE. On the High Pressure ECLIPSE valve we would recommend less then a 20 Flow Rate setting on the fog machine remote. On the Low Pressure ECLIPSE valve we would recommend Less then a 25 Flow Rate setting on the fog machine remote.
9. Wrong Fluid is being used. Ultratec Special Effects Molecular should be the only fluid used. Longer lasting fogs can cause this but again it is not observed often. If another manufacturers fluid is used this will definitely cause this type of problem.
10. The ECLIPSE needs as much free air as possible to operate correctly. If the ECLIPSE is locked up in a confined area poor output and overheating of the fog machine will occur.
11. The ECLIPSE high or low pressure valve is defective, clogged or damaged and is not allowing enough liquid CO2 into the ECLIPSE .
12. The ECLIPSE is damaged and is not getting good air flow.
13. The internal air expanding unit is damaged or has come dislodged from it's mounting device. If you are experiencing a residue problem, and the above checklist has failed to solve the problem, please call Ultratec Special Effects or e-mail service at service@ultratecfx.com for assistance in rectifying the problem.

Maintenance

Exterior

To clean simply wash with mild soap and warm water.

Check the foam gasket that sits between the G3000/PFI9D and the Eclipse for any damage and replace if required.

Cover the hose ends and fittings when not in use to prevent dirt from clogging the valves.

Keep road case cover over the Eclipse System open when in use.

Interior

Drain any accumulated liquid from inside the Eclipse with the drain valve on the bottom right.

Wipe the down the fog mixing chamber with a clean dry cloth to remove any excess liquid.

TECH TIP: At the end of a show it's good practice to allow the fan to run without CO2 to dry out any moisture that may have collected during use.

Recommended Fluid

Quick Dissipating Fog Fluid: This fast dissipating fluid is great for applications or effects that require quick dissipation of fog. It produces excellent steam effects that resemble nitrogen bursts and it also keeps low-lying fog from rising too quickly when it is used with the ECLIPSE or LSX.

Extra Quick Dissipating Fog Fluid: Dissipates 2x the rate of Quick Dissipating Fog Fluid while maintaining similar characteristics.

Molecular Fog Fluid: A faster dissipation versus the Director's Choice Fog Fluid. This thick, clean, white fog is an optimal solution for a dense low-lying fog effect when chilled with the ECLIPSE or LSX machines.

All of our Fog Fluids are water based. Damage will occur if Haze Fluid is used in the G3000. There will always be some residue in the ECLIPSE as it is using two opposing forces to create the effect; hot fog and cold gas.



Hardware products come with a five-year warranty on parts and labor. If the unit in question has a material defect or fault that is caused in manufacturing, Ultratec Special Effects will provide free parts and labor to remedy the equipment. Ultratec Special Effects service department must be advised in a timely manner after defect appearance and the date of warranty request must be within five years of sale/purchase. Proof of sale and/or proof of purchase will be required for warranty to take effect.

Warranty service will be performed as follows: faulty parts will be repaired or replaced with the same or comparable parts, based on availability. Freight to our facility for warranty requests will be prepaid by the user/dealer. Upon completion of the repair, Ultratec Special Effects will return the unit via the most economical means available. Should you require the item express-returned, the user/dealer is responsible for indicating this request and for any difference in freight cost.

Warranty will be voided, and customer will lose all rights guaranteed by the warranty if any of the following are observed/occur:

If any non Ultratec Special Effects fluid is used at any point of operation.

If any adjustments or repairs are done to the machine in question by repair technicians not authorized by Ultratec Special Effects.

If our repair technicians observe any signs of incorrect handling/treating of machine in question.

Warranty services do not cause an extension of the warranty nor does a repaired product start a new warranty. This warranty only applies to the product supplied by Ultratec Special Effects, Ultratec Special Effects is not responsible for any losses, costs, or damages from the use of a defective product.

Any additional costs incurred are the responsibility of the Dealer and/ or the customer.

An RA (Return Authorization) number must be noted on the outside of each box being returned to our facility. Any package(s) without an RA number clearly marked, will not be accepted by our receiving department.

Export Distributors are required to carry out the warranty repair, parts will be supplied by Ultratec.

Please do not forget to remove any liquid from the machine when sending in for repair.

Please remember to include the RA Number on all items being shipped in for repairs.

To request a Return Authorization number please refer to our website - instructions below:

- 1) www.ultratecfx.com
- 2) Click on the SUPPORT tab along the top of the screen
- 3) Click on REQUEST RMA from the pull down
- 4) Fill in the required information
- 5) Click on "SEND" button

If you have any questions or require assistance please contact service at 519-951-3355/866-534-5557 or by email at Service@Ultratecfx.com.

Contact Us

Head Office

Ultratec Special Effects
1960 Blue Heron Drive
London, Ontario N6H 5L9
Direct: 519-659-7972
Toll Free: 800-388-0617
Fax: 519-659-7713

Europe Office

Ultratec Special Effects GmbH
Dieselstrasse 30-40
60314
Frankfurt am Main
Germany
Direct: 49-69-87-000-1850
Fax: 49-69-87-000-1899

USA Shipping Address

(For All USA Repairs)
Ultratec Special Effects
640 Gadson Street
Groveland, Florida 34736

Canadian Shipping Address

(For All Canadian Repairs)
Ultratec Special Effects
1960 Blue Heron Drive
London, Ontario N6H 5L9

